

123MFパイプ

『123MFパイプ』は、コンクリートの設計基準強度123N/mm²の節付PHCパイプであり、(一財)日本建築センター基礎評定委員会の評定を取得した製品です。

【標準断面図】

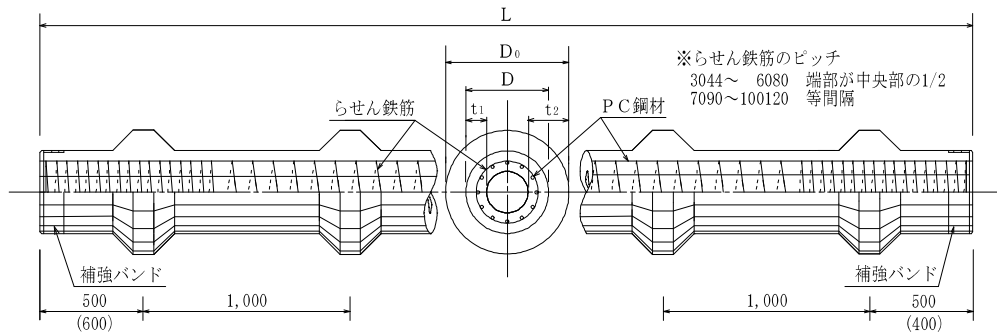

【設計諸数値】

■コンクリートの許容応力度

くいの種類	基準強度 (N/mm ²)	長期許容応力度 (N/mm ²)			短期許容応力度 (N/mm ²)		
		圧縮	曲げ引張	斜張	圧縮	曲げ引張	斜張
123MFパイプ	A	123	35.0	1.0	1.2	70.0	2.0
	B			2.0			4.0
	C			2.5			5.0

【断面性能表】 (3044~100120)

呼び名	種類	有効プレ ストレス (N/mm ²)	外 径		厚 さ		長さ L (m)	軸 部 断面積 A×10 ² (mm ²)	P.C鋼材			換 算 断面積 Ae×10 ² (mm ²)	換算断面 二次モーメント Ie×10 ⁴ (mm ⁴)	参考 質量 W (t/m)
			軸部 D (mm)	節部 D ₀ (mm)	軸部 t ₁ (mm)	節部 t ₂ (mm)			径 (mm)	本数	断面積 Ap (mm ²)			
※3044	A	4.0	300	440	60	130	2~13	452	7.1	6	240	462	35,299	0.148
	B	8.0							9.0	8	512	472	36,107	
	C	10.0							9.0	10	640	478	36,482	
3045	A	4.0	300	450	60	135	2~13	452	7.1	6	240	462	35,299	0.150
	B	8.0							9.0	8	512	472	36,107	
	C	10.0							9.0	10	640	478	36,482	
※3550	A	4.0	350	500	60	135	2~13	547	7.1	7	280	558	61,102	0.179
	B	8.0							9.0	10	640	573	62,653	
	C	10.0							9.0	12	768	578	63,199	
※4050	A	4.0	400	500	65	115	2~15	684	7.1	10	400	700	101,820	0.200
	B	8.0							9.0	12	768	715	103,940	
	C	10.0							10.7	11	990	724	105,270	
4055	A	4.0	400	550	65	140	2~15	684	7.1	10	400	700	101,820	0.219
	B	8.0							9.0	12	768	715	103,940	
	C	10.0							10.7	11	990	724	105,270	
4560	A	4.0	450	600	70	145	2~15	836	9.0	8	512	856	159,660	0.263
	B	8.0							9.0	16	1,024	877	163,350	
	C	10.0							10.7	14	1,260	886	165,150	
5065	A	4.0	500	650	80	155	2~15	1,056	9.0	9	576	1,079	246,280	0.325
	B	8.0							10.7	14	1,260	1,106	252,420	
	C	10.0							10.7	17	1,530	1,117	254,820	
6075	A	4.0	600	750	90	165	2~15	1,442	9.0	12	768	1,473	493,420	0.434
	B	8.0							10.7	18	1,620	1,507	504,660	
	C	10.0							10.7	23	2,070	1,525	510,560	
6080	A	4.0	600	800	90	190	2~15	1,442	9.0	12	768	1,473	493,420	0.484
	B	8.0							10.7	18	1,620	1,507	504,660	
	C	10.0							10.7	23	2,070	1,525	510,560	
7090	A	4.0	700	900	100	200	2~15	1,885	10.7	11	990	1,925	890,820	0.615
	B	8.0							10.7	22	1,980	1,964	909,850	
	C	10.0							12.6	22	2,750	1,995	924,650	
80100	A	4.0	800	1000	110	210	2~15	2,384	10.7	14	1,260	2,434	1,486,900	0.761
	B	8.0							10.7	28	2,520	2,485	1,518,600	
	C	10.0							12.6	28	3,500	2,524	1,543,300	
90110	A	4.0	900	1100	120	220	2~15	2,941	10.0	20	1,570	3,004	2,338,200	0.922
	B	8.0							10.0	40	3,140	3,067	2,387,200	
	C	10.0							11.2	40	4,000	3,101	2,414,000	
100120	A	4.0	1000	1200	130	230	2~15	3,553	10.0	24	1,884	3,628	3,509,700	1.097
	B	8.0							10.0	48	3,768	3,704	3,582,700	
	C	10.0							11.2	48	4,800	3,745	3,622,700	

※印は弊社営業担当にご相談ください。
備考) 複数の仕様があるため、代表的な値を記載しております。